

# FINSBURY/ MAINSFLO

## Owners Manual



### **⚠ WARNING**

This equipment must be installed and serviced by a qualified technician. Improper installation can create electrical hazards which could result in property damage, serious injury or death. Improper installation will void the warranty.



**Notice to Installer**  
this manual  
must be given to the owner/ operator of this equipment.

# IMPORTANT SAFETY INSTRUCTIONS

When installing and using this electrical equipment, basic safety precautions should always be followed, including the following:

## READ AND FOLLOW ALL INSTRUCTIONS



**DANGER**

Do not block the pump suction, as this will cause severe or fatal injury if blocked with the body.



**WARNING**

To reduce the risk of injury, do not permit children to use this product unless they are closely supervised at all times.

Incorrectly installed equipment may fail, causing severe injury or property damage. Refer to the Installation instructions.

### **~ IMPORTANT ELECTRICAL NOTICE ~**

*The electrical installation is to be done by a licensed electrician.*

*Each pump requires a circuit breaker to separate the pump from the electrical supply.*

*The contact separation has to provide full disconnection in all poles under overvoltage category III conditions.*

*If the pump is to be installed on a swimming pool or pond situation it is MANDATORY that an earth leakage circuit breaker with a rated tripping current not exceeding 30mA be installed.*

*Check the pumps name plate for the following: Voltage, Amp draw and Cycle.*

*The power cord, including the ground wire shall have a quality of 245 IEC66 (HO7RN-F) for models greater than 1Kw power input.*

*For models less than 1Kw input the quality shall be of 245 IEC57 (H05RN-F).*

*All installations must comply with local codes, based on IEC 364-7-702 requirements.*

## SAVE THESE INSTRUCTIONS

## GENERAL SAFETY RULES

1. The equipment mentioned in the manual are specially designed as household pressure pump.
2. They are designed to work with clean water at a temperature not exceeding 35 degrees Celsius (95 degrees Fahrenheit).
3. The installation should be carried out in accordance to the safety instructions of swimming pools, especially Standard HD 384.7.702, and the specific instructions for each facility.
4. The rules enforce on accident prevention should be carefully followed.
5. Any modification of the pump requires the prior consent of the manufacturer. Original replacement parts and accessories authorized by the manufacturer ensure a high level of safety. The manufacturer of the pump assumes no liability for the damage and injuries caused by unauthorized replacement parts and accessories.
6. During operation, some parts of the pump are subject to dangerous electric voltage. Work may only be performed on each pump or on the equipment connected to it after disconnecting them from the mains power, and after disconnecting the starting device.
7. The user should make sure that assembly and maintenance tasks are carried out by qualified authorized persons and that these persons have first carefully read the instructions for service and installation.
8. The operating safety of the pump is only guaranteed if the installation and service instructions are correctly followed.
9. The limit values stated in the. Technical table should not be exceeded under any condition.
10. In the event of defective operation or fault, contact the technical support department of the manufacturer or its nearest authorized agents.
11. If the supply cord is damaged, it must be replaced by an authorized service agent.
12. This appliance is not intended for use by persons (including children) with reduced physical, sensory or mental capabilities, or lack of experience and knowledge, unless they have been given supervision or instruction concerning use of the appliance by a person responsible for their safety.
13. The appliance is not intended for use by young children. Young children should be supervised to ensure that they do not play with the appliance.

# Table of Contents

<b>INTRODUCTION</b> .....	01
<b>APPLICATION SUITABILITY</b> .....	01
<b>ASSEMBLY &amp; INSTALLATION</b> .....	01
<b>OPERATION</b> .....	05
<b>PRESSURE TANK AIR CHARGE</b> .....	06
<b>TROUBLESHOOTING GUIDE</b> .....	07

## **INTRODUCTION**

Congratulations on purchasing your Waterco pump. This unit has been designed to pump water at a constant pressure no matter how many outlets are opened.

Your pump will provide you many years of trouble-free service, providing you adhere to the correct installation and operation instructions specified below.

The Waterco Finsbury/ Mainsflo pump will function correctly with or without a pressure pack. If no pressure pack is used, the pump will run whenever water is demanded from the unit. If a pressure pack is employed, the pump will run when the pressure pack is empty and stop once it is full. Pressure packs are available in 1, 2.75 & 4 litre sizes.

## **APPLICATION SUITABILITY**

The Waterco Finsbury/ Mainsflo range of pumps are designed, engineered and manufactured for pumping abrasive-free potable water.

Use for pumping liquids outside of these parameters will void the warranty unless express approval in writing has been received from Waterco Limited.

## **ASSEMBLY & INSTALLATION**

### **Pre Installation Checks**

1. Check that the area where the pump is to be located is as close as possible to the water supply, is flat and water will drain away easily from the area.
2. Check that the power supply to the pump meets the specification listed on the pump name plate.
3. Check that adequate housing and protection from the weather is available that will give proper ventilation to the unit (The pump motor cooling fan must have a minimum clearance of 150mm).

## Assembling the Waterco Finsbury/ Mainsflo Unit

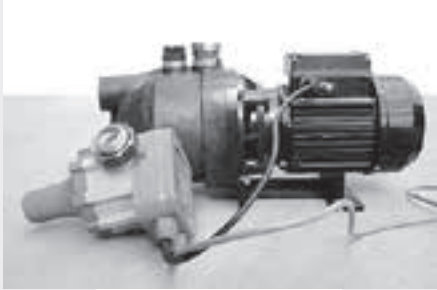

**Pump and Controller**



**Pressure Pack and Tee Fitting  
(Optional)**

***Figure 1: Contents of the Boxes***

Upon purchase, some minor assembly of the unit will be required before installation. Follow the steps below and the assembly will be finished before you know it.

1. Locate the pump in the desired position.
2. Place the controller onto the pump so it is facing the desired position and tighten the brass barrel union.



3. If you have purchased a pressure pack;
  - a. Wrap 3-4 turns of Teflon tape onto the male threaded end of the Pressure Pack and screw on the Tee fitting.



- b. Wrap 3-4 turns of Teflon tape onto the male threaded end of the controller. Take the Pressure Pack and Tee Fitting and screw onto the pump controller.



4. Readjust the direction of the pump controller and the tee fitting if necessary. The brass barrel union should be tightened using a suitably sized wrench. All other connections should be hand tight.



**WARNING**

Do not tighten any connections by twisting the pressure pack. Over-tightening may result.

## Methods of Installation

The Waterco Finsbury/ Mainsflo Pressure System can be installed in two ways:

### **Flooded Suction**

- A good quality check valve should be installed in the suction line.

### **Suction Lift (maximum 2 metres)**

- Fit a good quality foot or gate valve to the end of the suction pipe nearest the water supply (furthest from the pump). This will allow for easy priming of the pump. If the suction lift required by the pump is too high, the system will not reach the required pressure and will not cut out automatically.

SUCTION LIFT

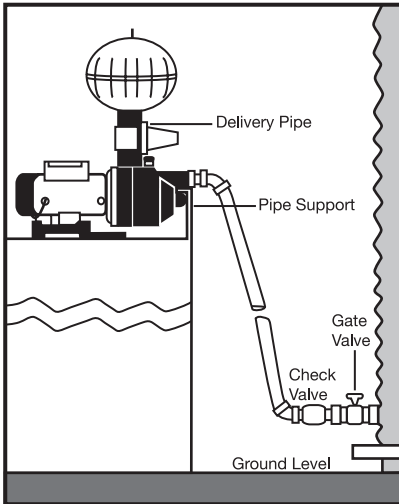

**NOTE : LAWS GOVERNING ELECTRICAL INSTALLATIONS MUST BE observed and electricians consulted where necessary.**

FLOODED SUCTION

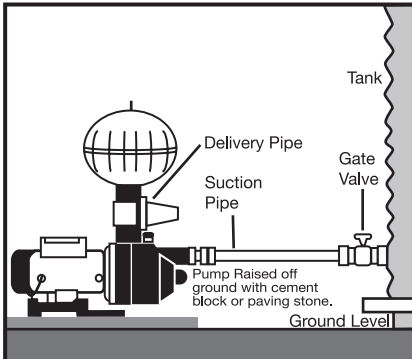

SUCTION LIFT

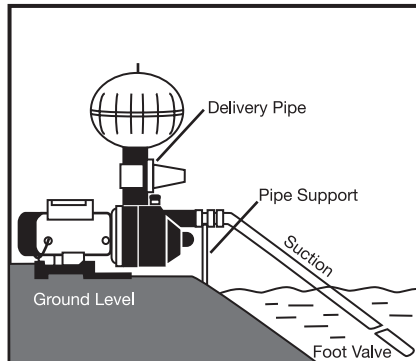

**Figure 2: Methods of Installation**



## Pipe Size

Suction Port: 25mm (1 inch) male BSP.

Delivery Port: 25mm (1 inch) female BSP.

Pipe runs in excess of 10 metres should use a minimum of 40mm (1 ½ inch) pipe.

## Pipe Supports

All pipe work must be supported separately from the pump otherwise distortion of the pump components could cause problems. Short pump components could cause problems. Short lengths of rubber hose can assist in alignment and also assist in reducing vibration through the system. Long lengths of PVC or poly pipe should be buried to keep the sun off them. This is essential as expansion of these pipes can put stress on the pump.

## Connecting to Mains Water Supply

If connecting this pump to the mains water supply, consult local codes for plumbing requirements.

## Water Hammer

Water Hammer may be caused by products such as automatic dishwashers and washing machines as a result of the quick action solenoid valves. If water hammer is evident, consult your plumber and have a water hammer arrester installed.

# OPERATION

## Priming the Pump

### *Flooded Suction*

- loosen the priming cap on the pump and gently open the gate valve at the tank and allow water to flow to the pump until all air is expelled via the cap.

### *Suction Lift*

- priming can take place through the removal of the priming cap if only a short pipe is employed. If a long pipe is used, a tee in the suction line of the size of the pipe can be of benefit for quick filling and venting to prime the system. When the pipe is full, replace plug and seal securely. Top up pump at priming point.



Make sure the pump is full of water before switching on. Damage may be caused through running the pump dry, as this will cause excessive wear to moving parts that depend on water for lubrication.

## Starting Up

Prime the pump as above. Open a tap on the delivery side. Switch on the power supply to the unit. The green “Power On” LED will glow, indicating power is being supplied to the unit. The pump will start running and the yellow “Pump On” LED will glow. If all goes well, water will begin to flow from the open tap. Close the tap and the pump will switch off when it has reached the correct pressure. Running time will vary depending on the size of the pressure pack but should not be much longer than 2-3 minutes.

If the red “Failure” LED glows, make sure there are no leaks in the suction line. Make sure the pump is primed by opening the priming cap and checking that it is full of water. Press “Restart” and the pump should start running again.

Once running, if the pump switches off for a short time and then starts up again, check that all taps are closed and that there are no leaks in the suction or delivery pipes. If this problem continues refer to the troubleshooting section. If the pump will not switch off after initial start up refer to the troubleshooting section.

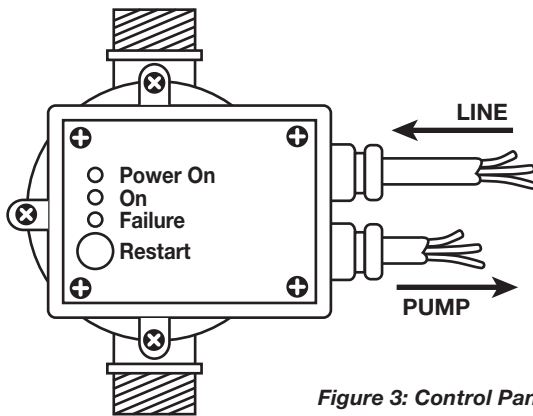

*Figure 3: Control Panel*

## PRESSURE TANK AIR CHARGE

To check the air pressure, proceed as follows:

1. Switch power off to pump
2. If on flooded suction close gate valve on tank outlet
3. Open a tap on discharge side of the pump and relieve all water pressure
4. Check the tank air charge with a tyre gauge and inflate if necessary

The Correct Air Pressure Settings are:

Waterco Finsbury/ Mainsflo 48, 65, 87 & 90 – 200 kPa (29 PSI).

## TROUBLESHOOTING GUIDE

Waterco strongly recommends you have a qualified service technician service your pump. However, many problems may be solved by consulting the table below.

SYMPTOM	POSSIBLE CAUSE	ACTION
<b>Motor won't start or run</b>	No power supply	Check for blown/ tripped fuses and replace/ reset.
	Defective wiring	Check for damaged or corroded power cables. Have an electrician replace.
	Motor burnt out	Have technician replace.
	Impeller jammed	Have a service technician inspect the unit.
	Low voltage supplied to unit	Check with power company to ensure correct voltage is being supplied.
<b>Motor runs hot and the automatic overload trips out</b>	Irregular voltage supply	Check voltage supplied to unit is within the limits specified on the pump name plate.
	Poor ventilation	Provide adequate ventilation. The pump motor cooling fan must have a minimum clearance of 150mm.
<b>Red "Failure" LED glows</b>	Air leak in suction pipe	Make sure all pipe joints are air tight. Re-prime pump. Press "Restart".
	Pump will not prime	Add water slowly so as to expel air from the pump and pipe system. Press "Restart". Repeat as necessary. Check suction pipe and foot valve for leaks.
	Foot valve stuck or strainer clogged	Remove, repair and clean.
	Water level below foot valve	Lower foot valve deeper into well.

### WARNING

If the Waterco Limited pump is within the stated warranty period and you experience faults always contact your supplier or the nearest Waterco Limited branch for advice. Failure to do this may void the warranty. Refer to warranty documentation supplied with the pump.

All electrical work is to be carried out by a qualified electrician. Under no circumstances should you attempt repairs on the electrical components of Waterco Limited pumps unless you are qualified to do so.

## **OFFICES - AUSTRALIA**

NSW - Sydney  
(HEAD OFFICE)  
Tel : +61 2 9898 8686

VIC/ TAS - Melbourne  
Tel : +61 3 9764 1211

WA - Perth  
Tel : +61 8 9273 1900

QLD - Brisbane  
Tel : +61 7 3299 9900

SA/ NT - Adelaide  
Tel : +61 8 8244 6000

ACT Distributor  
Tel : +61 2 6280 6476

## **OFFICES - OVERSEAS**

Waterco USA  
Augusta, USA  
Tel : +1 706 793 7291

Waterco Canada  
Longueuil, Qc, Canada  
Tel : +1 450 748 1421

Waterco (Europe) Limited  
Sittingbourne, Kent. UK  
Tel : +44(0) 1795 521 733

Waterco France  
SAINT PRIEST, France  
Tel : +33 (0)4 72 79 33 30

Waterco (NZ) Limited  
Auckland, New Zealand  
Tel : +64 9 525 7570

Waterco (C) Limited  
Guangzhou, China  
Tel : +8620 3222 2180

Waterco (Far East) Sdn. Bhd.  
Selangor, Malaysia  
Tel : +60 3 6145 6000

PT Waterco Indonesia  
Jakarta, Indonesia  
Tel : +62 21 4585 1481

Waterco International Pte Ltd  
Singapore  
Tel : +65 6344 2378

# **WATERCO**

Waterco Limited ABN 62 002 070 733

Member  
**WATER  
QUALITY  
ASSOCIATION** ®

